



450SE V2

INSTRUCTION MANUAL



Thank you very much for buying a COPTER X 450SEversion 2 RC product. In order to be able to use this product safely, please read this manual before flying the helicopter. Please fly the helicopter safely observing all rules and manners after having fully understood the flight precautions, the unit's capabilities, and the best way to fly it. Be sure to retain the manual for future reference, routine maintenance, and tuning.

IMPORTANT NOTES

- This helicopter is recommended for skilled intermediates and advanced RC helicopter flyers.
- Make sure to read and follow all the instructions in this manual, including all accessories.
- Should any problems arise, please confirm with an experienced RC helicopter personnel / instructor before introductory flight.
- Always find an experienced and / or qualified personnel / instructor for per flight inspection.
- Make sure flight vicinity is in an open space; free of crowds, obstacles, and buildings. Failure to abide may cause accidental and potentially hazardous encounters.
- Introductory flight should incorporate only the basic maneuvers (hovering, linear movements), until stick feel is mastered.

SAFETY NOTES

Locate an appropriate location :

R/C helicopters fly at very high speeds, thus posing a certain degree of danger. Choose an appropriate location. A clear large room such as a Gymnasium, basketball court, warehouse. Do not fly the model on residential or commercial places such as near houses or buildings. Do not fly near electrical poles or high voltage cables that may cause radio interference. Do not fly model on inclement weather such as rain, wind if snow.

Acquire the assistance of an experience pilot:

Before starting up the model it is best that it is checked by someone that is experienced with this models, Parts checking prior flight is mandatory. On the flying field before actual power up of model and transmitter make sure the no other pilots have the same frequency. Frequency interference can cause your model and other model of same frequency to crash.

For first time pilots its highly recommended that you use a simulator (Computer based flight simulator) for enhancement of flight skills

Aware of moving parts:

During actual operation of the helicopter, the main rotor blades will be spinning at a very high rate of speed. The blades are capable of imposing serious bodily injury and damage to the environment. Be careful on body parts such as hand, eyes, arms. Also be cautious of loose clothing, can be sucked up by the rotating blades.

Do not turn your away you eyes when the model is turned on or in use. Never leave the model unattended. Immediately turn off the model and transmitter after use.



PREVENT MOISTURE



R/C models are composed of many precision electrical components that is sensitive to moisture and water. Keep away from water sources or moisture related places.

The introduction of moisture in any form can seriously damage the electrical parts of the model that can cause malfunction and premature flight patterns.

KEEP AWAY FROM HEAT



R/C models are made of some parts plastic.

Make sure to store the model away from head producing appliances such as heaters or stoves. It is best to keep the model indoors in a controlled cool environment with ambient room temperature.

RADIO TRANSMITTER AND ELE CTRIONIC EQUIPMENT REQUIRED FOR ASSEMBLY



Transmitter
(6-channel, helicopter system)



Reciever
(6-channel, or more)



9g Micro Servo x 3 pcs.
5g Micro Servo x 1 pcv



Gyro

TOOL REQUIRED FOR ASSEMBLY



SCISSORS



CUTER BLADE



LIQUID THREAD LOCK



CA GLUE



BALL LINK PLIERS



PITCH GUAGE



Liquid Thread lock



Cyanoacrylate (CA)

NOTE : The following marks will be seen on the pages of this instruction manual. This designates location and contact points that needs application of adhesive. Liquid thread lock are usually used on metal to metal contact screws normally with fine pitch threading. For Metal to plastic CA can be applied screws designated as force threading or self tapping.

MAIN ROTOR INSTALLATION

Parts List							
No.	Parts #	Description	Specification	No.	Parts #	Description	Specification
1	CX450-01-21	Metal Rotor Housing	17x37x5x11mm	7	CX450-01-03	Bearing	ø2xø5x2.5mm
2	CX450-01-03	Flybar Seesaw Holder	36x15x6x6mm	8	CX450-01-04	Linkage Ball	ø4.75
3	CX450-01-03	Collar Bearing	ø2xø5x6x2.3mm	9	CX450-01-04	Machine screw	M2x6.5mm
4	CX450-01-03	Collar screw	M2 x 7mm	10	CX450-01-04	Washer	ø2xø3.8x0.5mm
5	CX450-01-01	Pin	ø 1.5x18.7mm	11	CX450-01-04	Collar Screw	M2X8mm
6	CX450-01-04	Mixing lever arm	31.15x5.5mm	12		Washer	ø2xø3.8x0.2mm

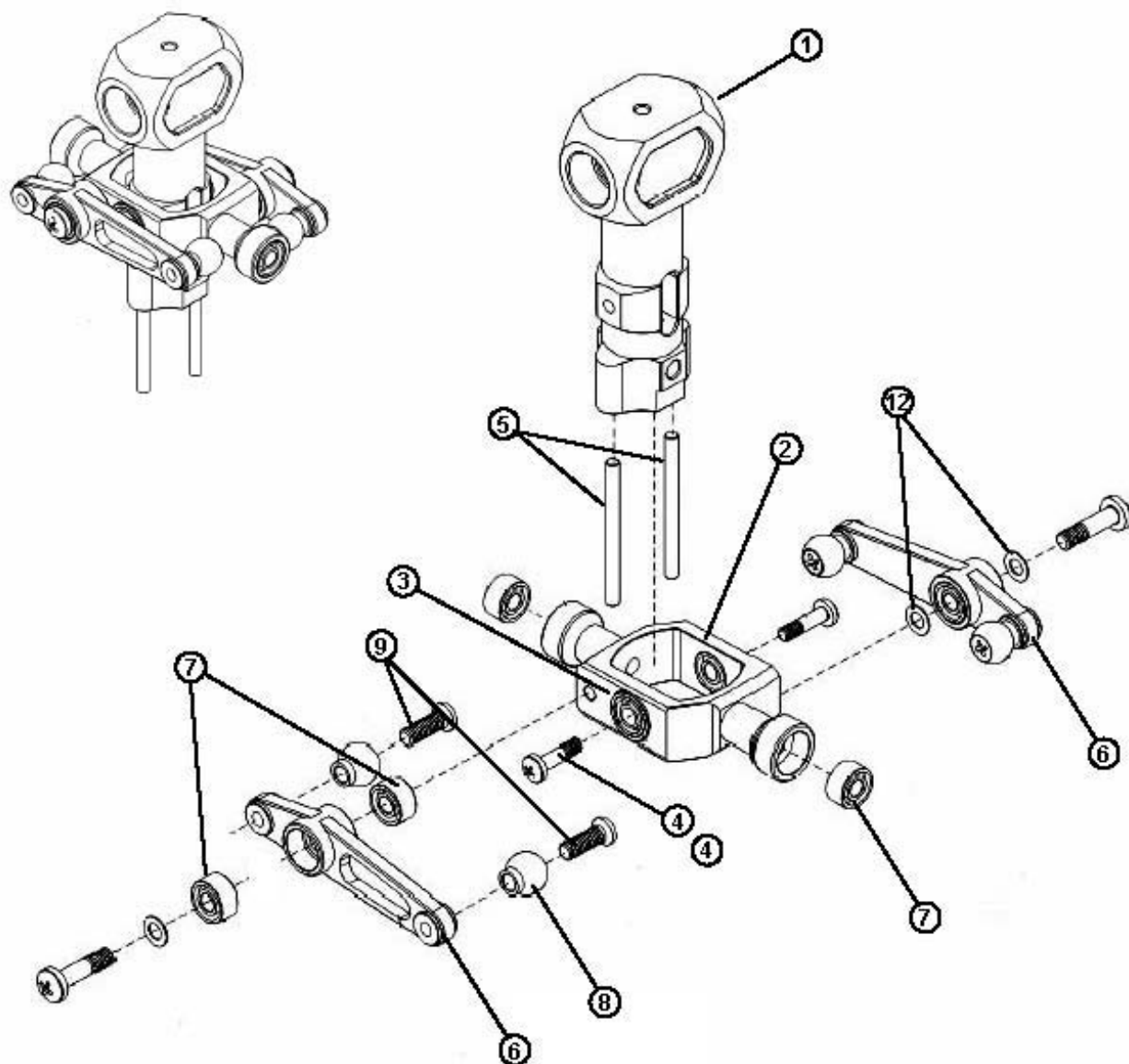

MAIN ROTOR INSTALLATION

Parts List							
No.	Parts #	Description	Specification	No.	Parts #	Description	Specification
13	CX450-01-22	Metal main rotor holder	17x37.5x11mm	26	CX450-01-05	Metal Flybar control lever	31.4x2.5.5mm
14	CX450-01-22	Bearing	ø4xø8x3mm	27	CX450-01-05	Washout Linkage	
15	CX450-01-22	Linkage ball	ø4.75	28	CX450-01-05	Collar Screw	M1.4x6.5mm
16	CX450-01-22	Machine screw	M2 x 6.5mm	29	CX450-01-05	Bearing	ø2xø5x2.5mm
17	CX450-01-22	Bearing	ø3x6x2.5mm	30	CX450-01-05	Linkage ball	ø4.75
18	CX450-01-22	Rubber O ring	ø4x6.5x2.0mm	31	CX450-01-05	Machine Screw	M2x6.5mm
19	CX450-01-22	Metal Colar	ø4x5.2x1.5mm	32	CX450-01-05	Machine Screw	M2x8mm
20	CX450-01-23	Feathering Shaft	ø4x40mm	33	CX450-01-05	Washer	ø2xø3.8x5mm
21	CX450-01-02	Washer	ø 2x5x0.4mm	34	CX450-01-05	Washer	ø2xø3.8x2mm
22	CX450-01-02	Socket Screw	M2 x 5mm	35	CX450-01-09	Socket Screw	M2x12mm
23	CX450-01-21	Screw	M2 x 6mm	36	CX450-01-09	Nut	M2
24	CX450-01-21	Metal Head Stopper	ø18x6mm	37	CX450-01-09	Main Shaft	ø5x116mm
25	CX450-01-06	Metal Washout base	ø5x10mm	38	CX450-01-22	Thrust Bearing set	ø3xø8x3.5mm

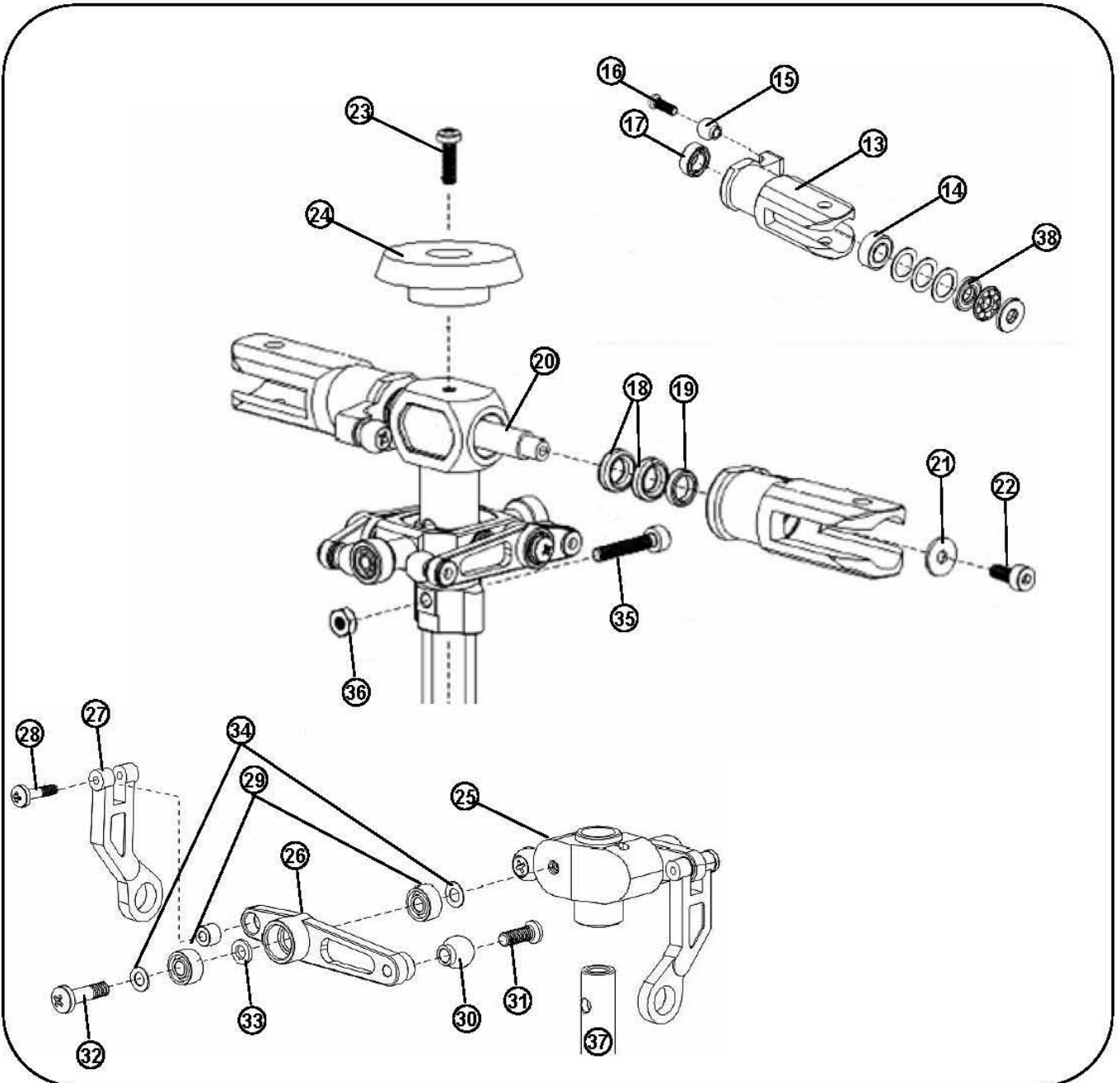

MAIN ROTOR INSTALLATION

Parts List

No.	Parts #	Description	Specification	No.	Parts #	Description	Specification
1	CX450-01-01	Main rotor holder	-	6	CX450-01-07	Set Screw	M3x3mm
2	CX450-01-02	Main Rotor housing	-	7	CX450-01-07	Mechanical Screw	M2x5mm
3	CX450-01-03	Seesaw holder	-	8	CX450-01-07	Control Rod	ø4.3x38.8mm
4	CX450-01-04	Metal Control Lever	-	9	CX450-01-07	T type control arm	38.3x4.5mm
5	CX450-01-08	Swashplate	-	10	CX450-01-10	Flybar Paddle	

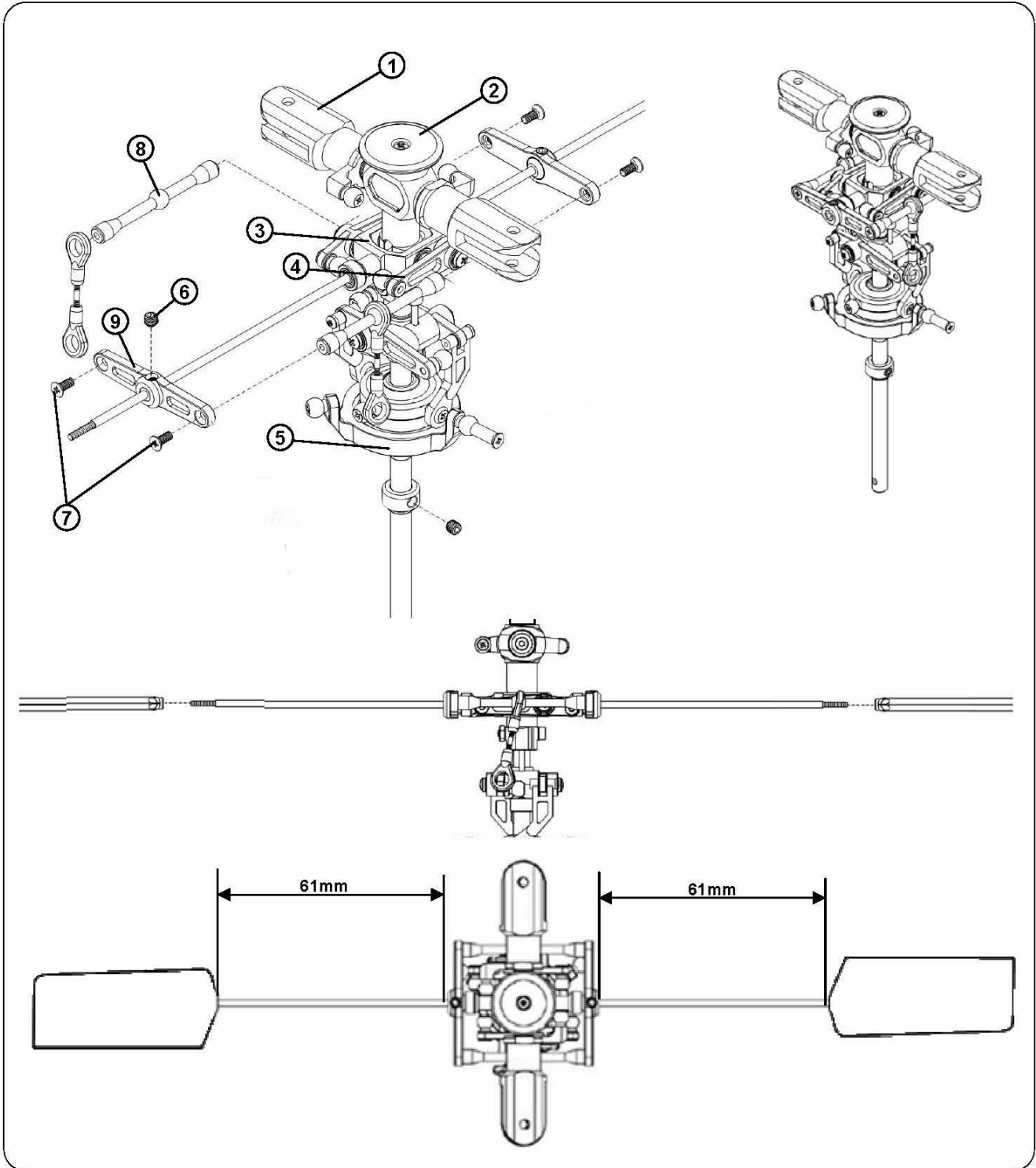

MAIN FRAME ASSEMBLY

Parts List							
No.	Parts #	Description	Specification	No.	Parts #	Description	Specification
1	CX450-03-09	Carbon Upper frame	Black carbon fiber	8	CX450-03-02	Bearing	ø5xø11x5mm
2	CX450-03-06	Battery mounting plate	50x36x1mm	9	CX450-03-05	Button head screw short	M2x4mm
3	CX450-03-05	Counter sunk bolt	ø4x22mm	10	CX450-03-05	Aluminum battery mounting plate	34.2x22.5x4.75mm
4	CX450-01-02	Button Head screw	M2x6mm	11	CX450-03-01	Tail boom lock	27.5x43.4x12.5mm
5	CX450-03-08	Aluminum washer	ø2xø5x2mm	12	CX450-03-03	Tail drive gear assembly	
6	CX450-03-06	Machine screw	M2x4mm	13	CX450-03-03	Upper bearing case	22x17x4.5mm
7	CX450-03-02	Main shaft mount	23x27x7mm	14	CX450-03-03	Lower bearing case	25x22x4.0mm

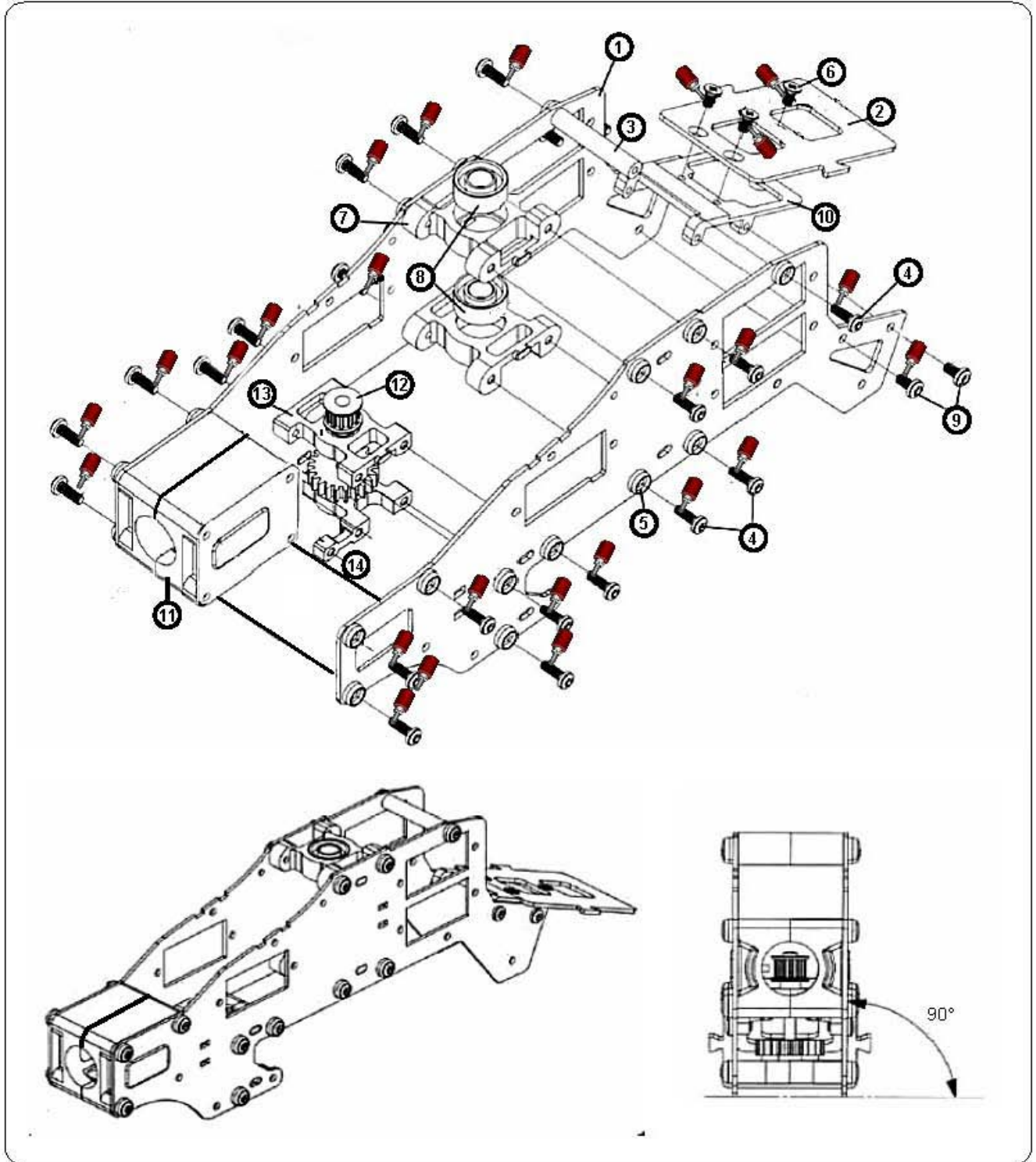

Parts List

No.	Parts #	Description	Specification	No.	Parts #	Description	Specification
15	CX450-03-06	Black Carbon lower frame	Black carbon fiber	24	CX450-03-08	Frame mounting bolt	ø4x22 mm
16	CX450-03-07	Bottom plate	172.5x39x5mm	25	CX450-03-04	Socket screw	M2x6.6mm
17	CX450-03-06	Self tapping screw	M2x6mm	26	CX450-03-04	Washer	ø2.6
18	CX450-03-08	Aluminum washer	ø2xø5x2mm	27	CX450-03-11	Canopy mounting bracket	ø5x24.5mm
19	CX450-03-03	Button head screw	M2x1.4mm	28		Nut	-
20	CX450-03-03	Button head screw	M2x6mm	29	CX450-03-10	Anti rotation bracket	
21	CX450-03-04	Metal Motor mount	36.4x39mm	30	CX450-03-10	Bracket washer	12x4.49x2mm
22	CX450-03-08	Aluminum link	ø5xø2x7.5mm	31	CX450-03-10	Self tapping screw	M2x6mm
23	CX450-03-08	Aluminum washer	ø2xø5x2mm				

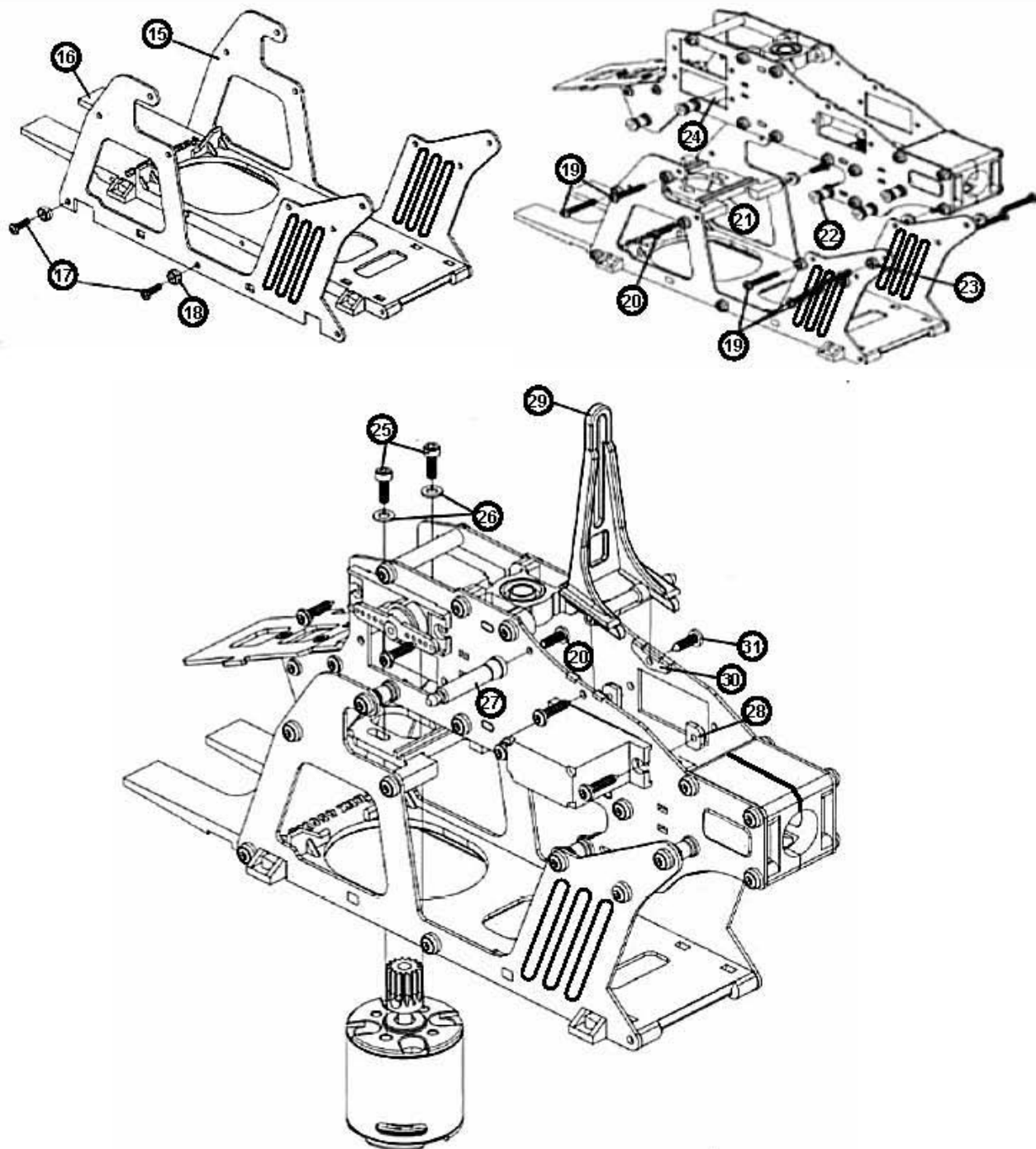

Parts List							
No.	Parts #	Description	Specification	No.	Parts #	Description	Specification
1	CX450-05-03	Main drive gear	150T	5	CX450-05-03	Autorotation tail drive gear	106T
2	CX450-05-03	Shaft ring	$\varnothing 8 \times \varnothing 6 \times 1.5 \text{mm}$	6	CX450-05-03	Main Gear Case	M2x12
3	CX450-05-03	One Way bearing	$\varnothing 6 \times \varnothing 10 \times 12 \text{mm}$	7	CX450-05-03	Socket screw	M2x12
4	CX450-05-03	Autorotation sleeve	$\varnothing 6 \times \varnothing 5 \times 21.5 \text{mm}$	8	CX450-05-03	nut	M2

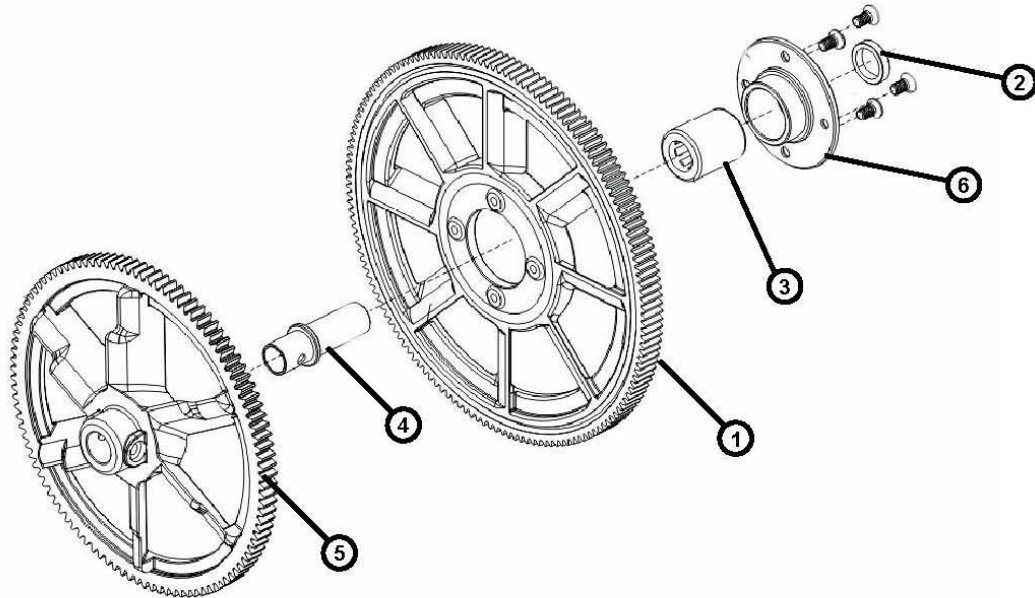

Align Hole on the autorotation sleeve with the bottom gear with a precision tool. Insert the M2x12mm screw and tighten with nut

Tighten the collar on the shaft make sure no movement on the shaft

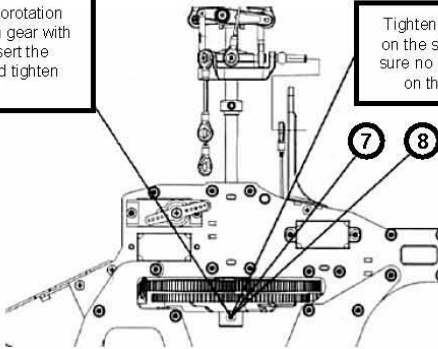

Set Backlash to at least 0.05mm distance.

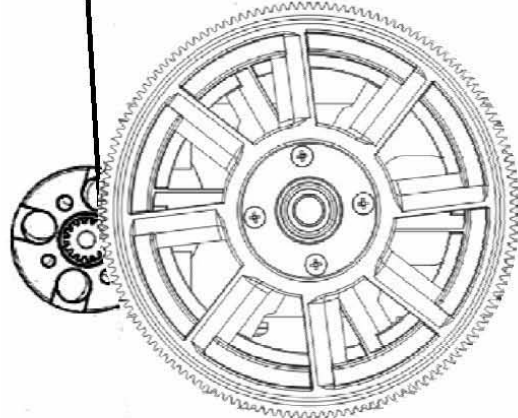
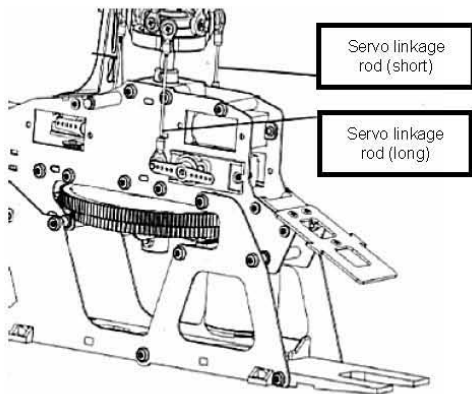

Parts List

No.	Parts #	Description	Specification	No.	Parts #	Description	Specification
1	CX450-04-01	Bump resistant Skid	-	4	CX450-04-02	Antenna holder	ø3x330mm
2	CX450-04-02	Skid Pipe	Aluminum blue	5	CX450-04-03	Landing skid nut	ø8.5ø5x10mm
3	CX450-04-02	Skid Pipe end cap	-	6	CX450-03-06	Self tapping screw	M2x8mm

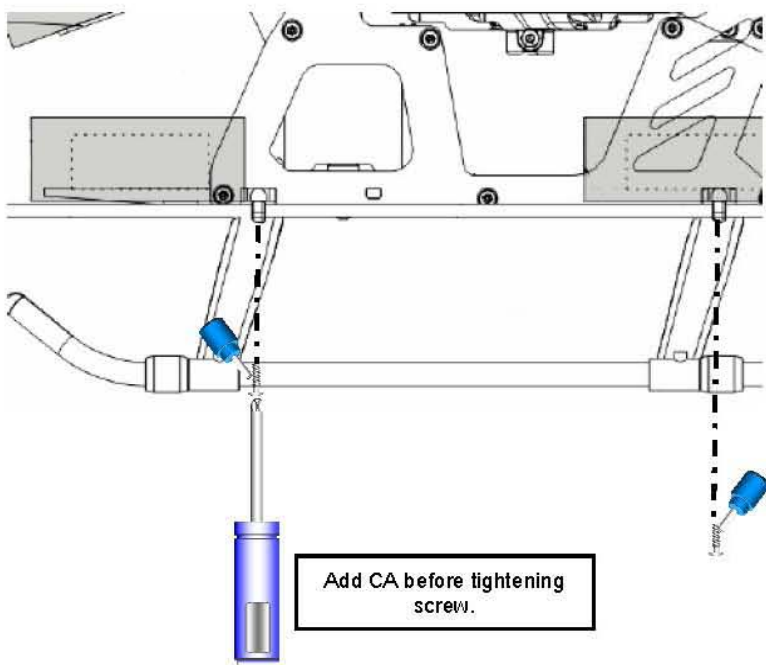
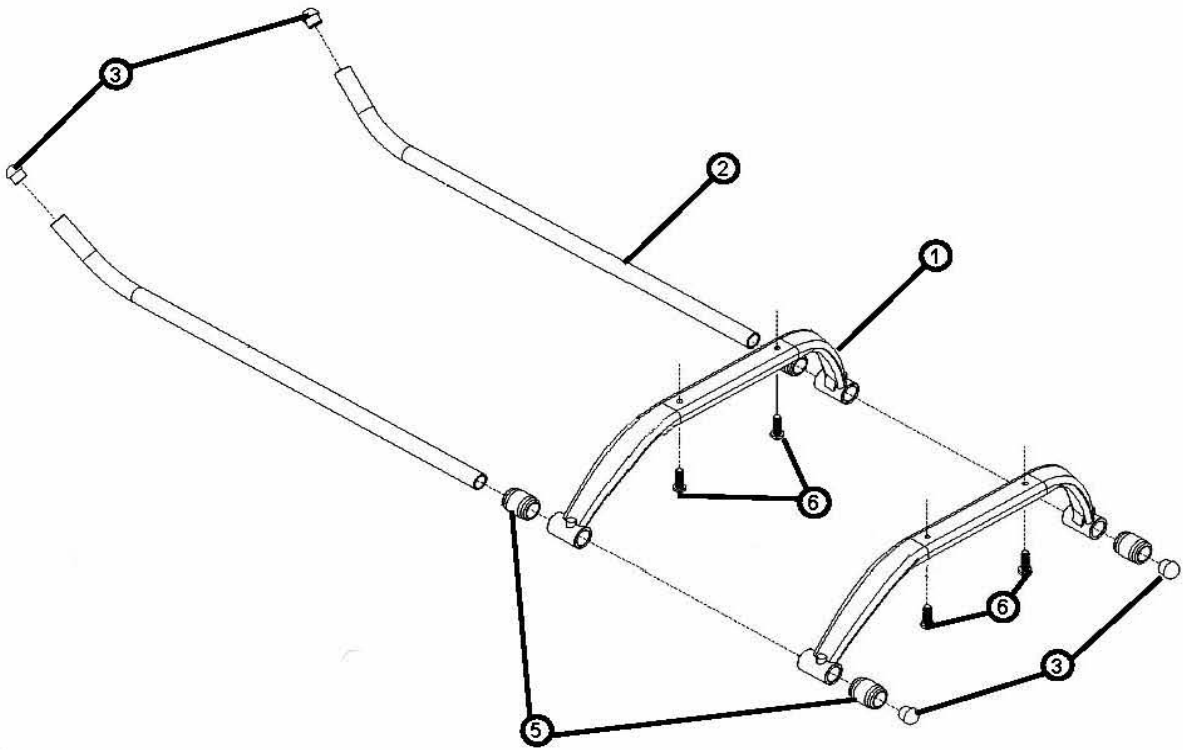

Add CA before tightening screw.

TAIL CASE ASSEMBLY

Parts List							
No.	Parts #	Description	Specification	No.	Parts #	Description	Specification
1	CX450-06-02	Tail rotor blade	-	14	CX450-02-01	Control arm holder	11 x 22mm
2	CX450-02-02	Socket Screw	M2 X 8mm	15	CX450-02-01	Bottom head screw	M2 x 14mm
3	CX450-02-02	Bearing	ø2Xø 5x2mm	16	CX450-02-01	Tail boom	ø12x347mm
4	CX450-02-02	Metal tail Rotor Holder		17	CX450-02-01	Washer	ø2x ø3.6x0.5mm
5	CX450-02-02	Socket Screw	M2 X 8mm	18	CX450-02-01	Bearing	ø2Xø 5x2.5mm
6	CX450-02-02	Bearing	ø3Xø 6x2.5mm	19	CX450-02-06	Tail Rotor Control arm	
7	CX450-02-02	Tail Rotor hub	ø8Xø 18.2mm	20	CX450-02-06	Stainless steel linkage ball	ø4.75
8	CX450-02-01	Tail gear case		21	CX450-02-06	Collar Screw	M2 x 8mm
9	CX450-02-01	Tail Drive Belt		22	CX450-02-06	Control Ball link	
10	CX450-02-01	Tail Pulley Assembly		23	CX450-02-06	Collar A	
11	CX450-02-01	Alimunim Collar	ø3Xø 4x8.5mm	24	CX450-02-06	Collar B	
12	CX450-02-01	Metal tail unit housing (R)		25	CX450-02-06	Tail pitch assembly	
13	CX450-02-01	Metal tail unit housing (L)		26	CX450-02-04	Tail Rotor Shaft Assembly	

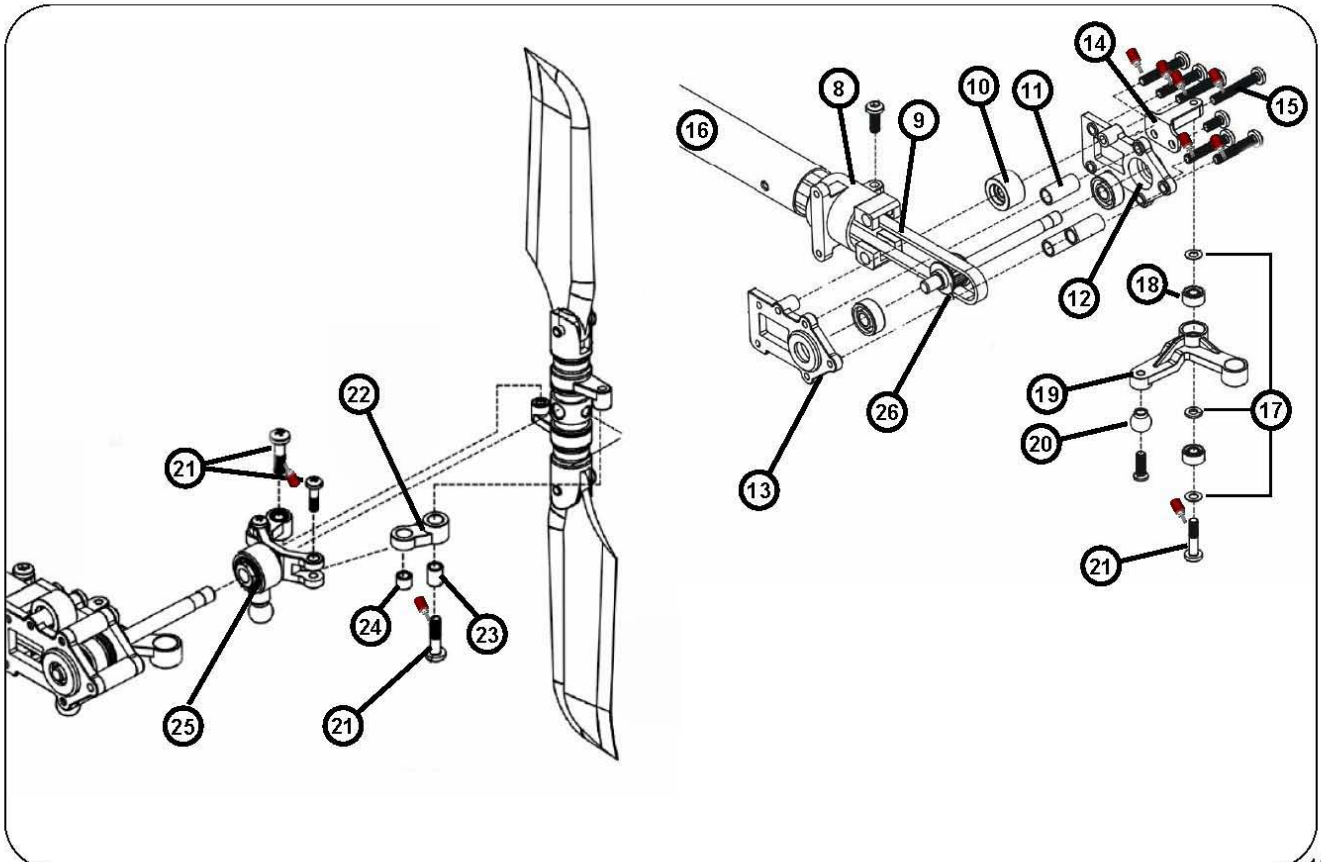
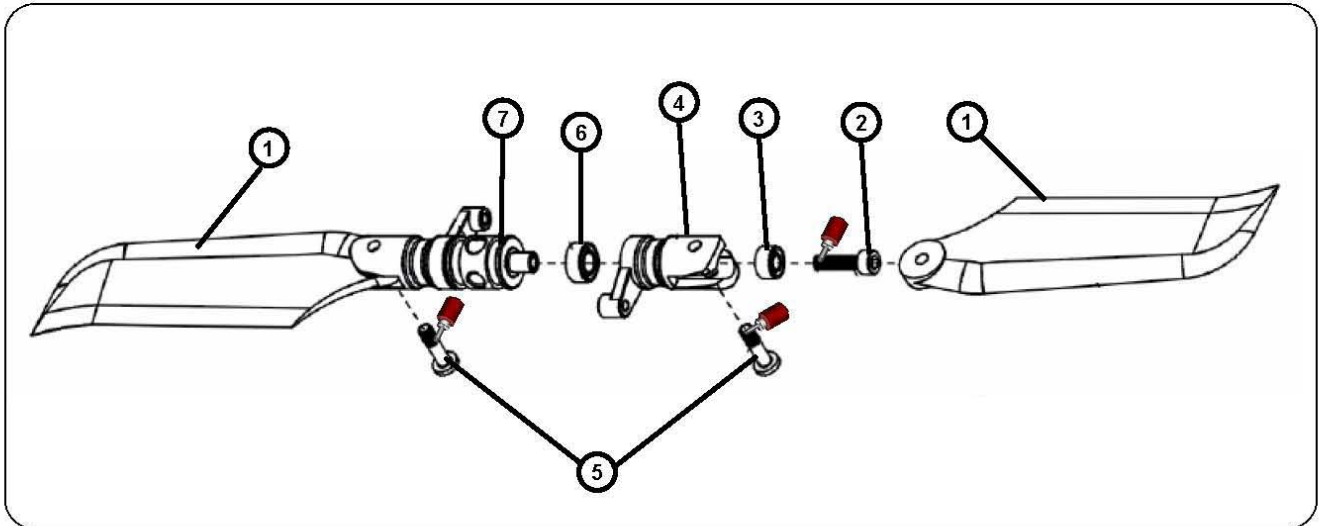

TAIL ROTOR & BOOM ASSEMBLY

Parts List							
No.	Parts #	Description	Specification	No.	Parts #	Description	Specification
1	CX450-02-05	Tail rotor drive belt	397T	10	CX450-06-03	Carbon Fiber vertical stabilizer	71x115x1mm
2	CX450-07-04	Tail servo mount		11	CX450-02-00	Button screw	M2x4mm
3	CX450-07-04	Tapping screw	M2x6mm	12	CX450-07-01	Tail linkage Rod	ø2x250mm
4	CX450-07-02	Tail boom brace	ø3x205mm	13	CX450-07-01	linkage Rod A	ø1.3x16mm
5	CX450-07-02	Tail boom brace terminal		14	CX450-07-01	Linkage rod B	ø1.3x12.5mm
6	CX450-03-08	Aluminum Washer	ø2Xø5x2mm	15	CX450-07-01	Ball link	
7	CX450-06-03	Self Tapping screw	M2x8mm	16	CX450-07-02	Collar screw	M2x9mm
8	CX450-07-05	Bracket		17	CX450-03-08	Alumuminum washer	ø2x5x2mm
9	CX450-06-03	Carbon Fiber horizontal stabilizer	42.8x120x1 mm				

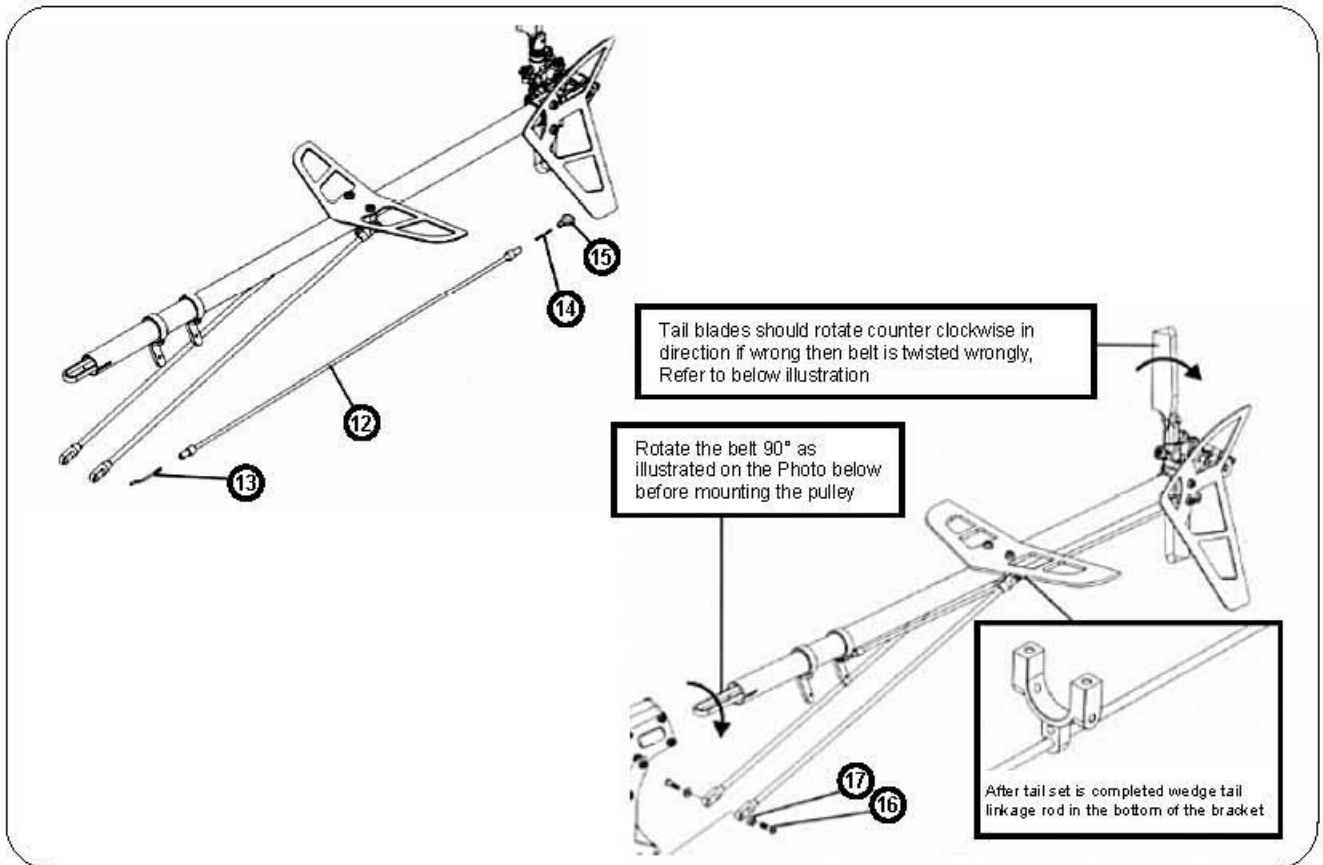
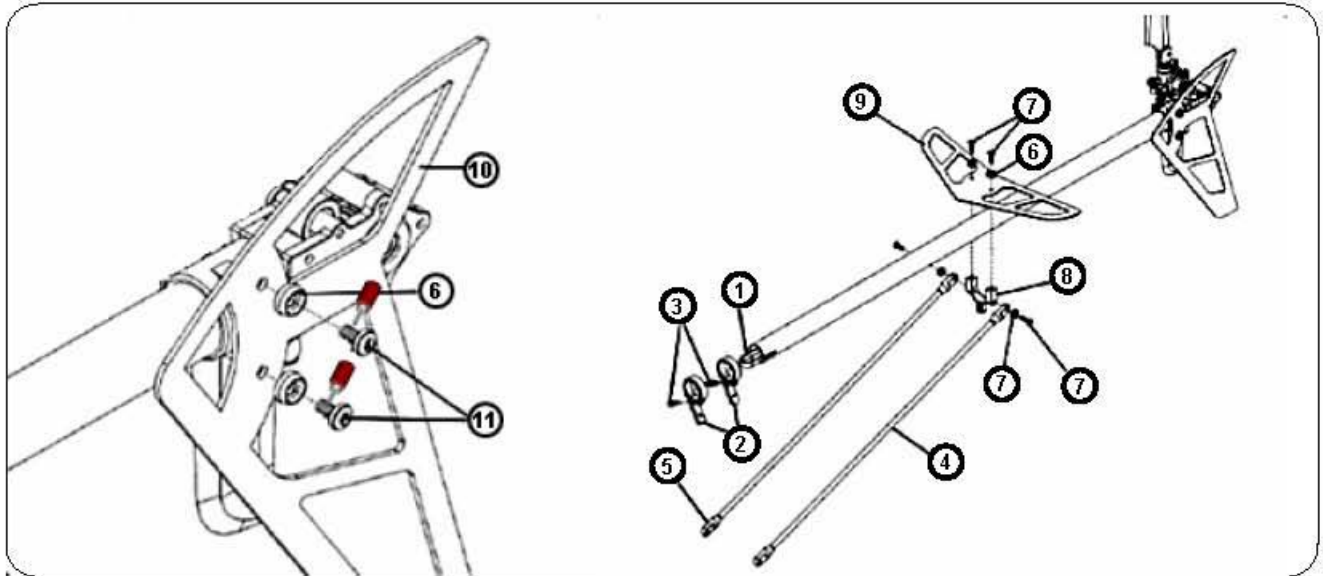

Parts List

No.	Parts #	Description	Specification	No.	Parts #	Description	Specification
1	CX450-02-05	Canopy		2	CX450-06-03	Canopy nut	ø2.3x3.4x7x3.6mm

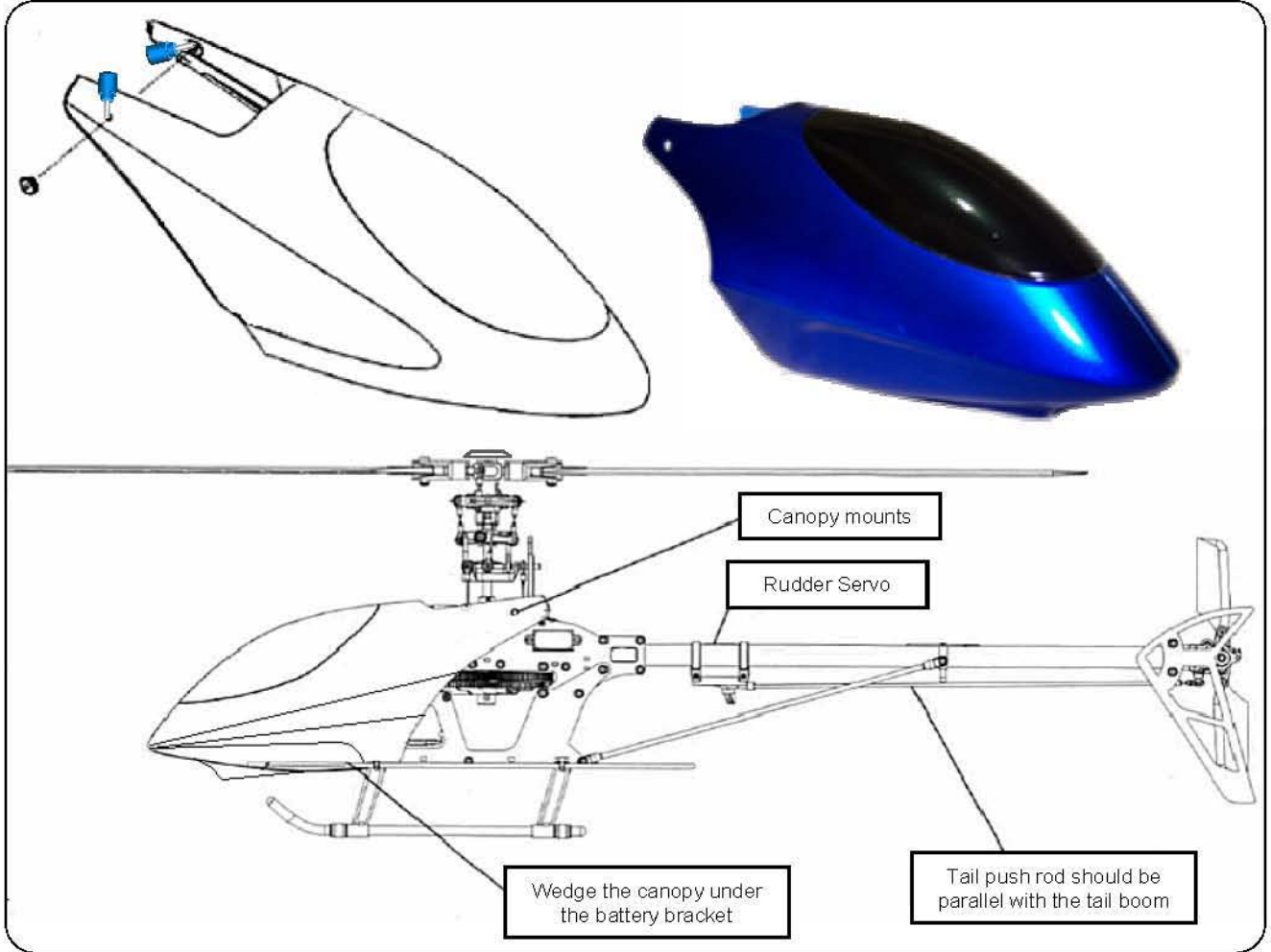

HITEC – FUTABA ELECTRICAL LAYOUT

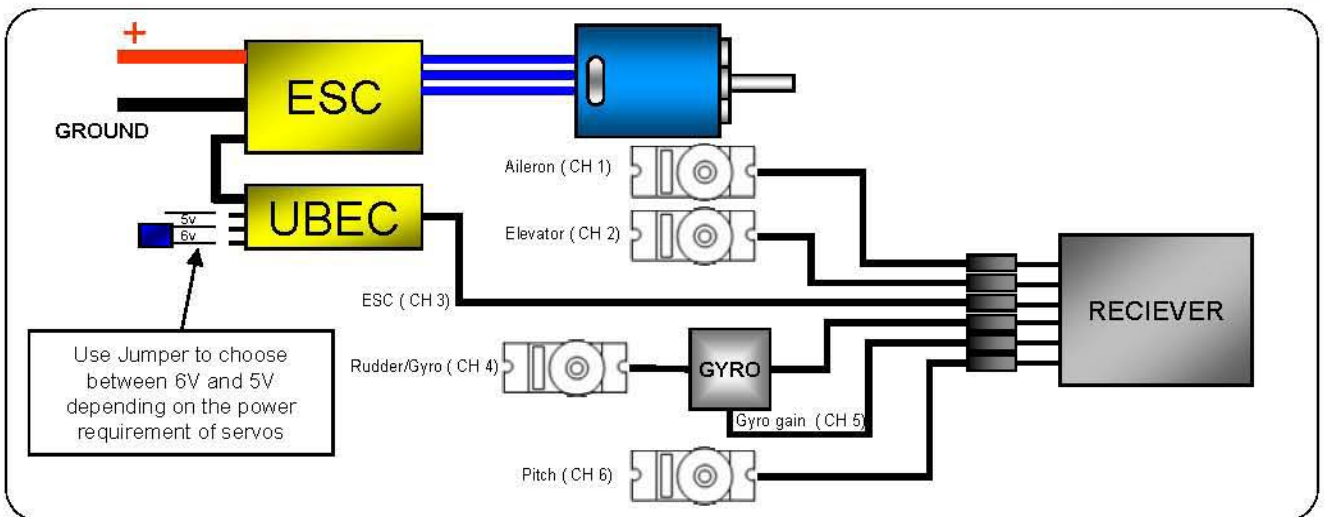

Linkage rod

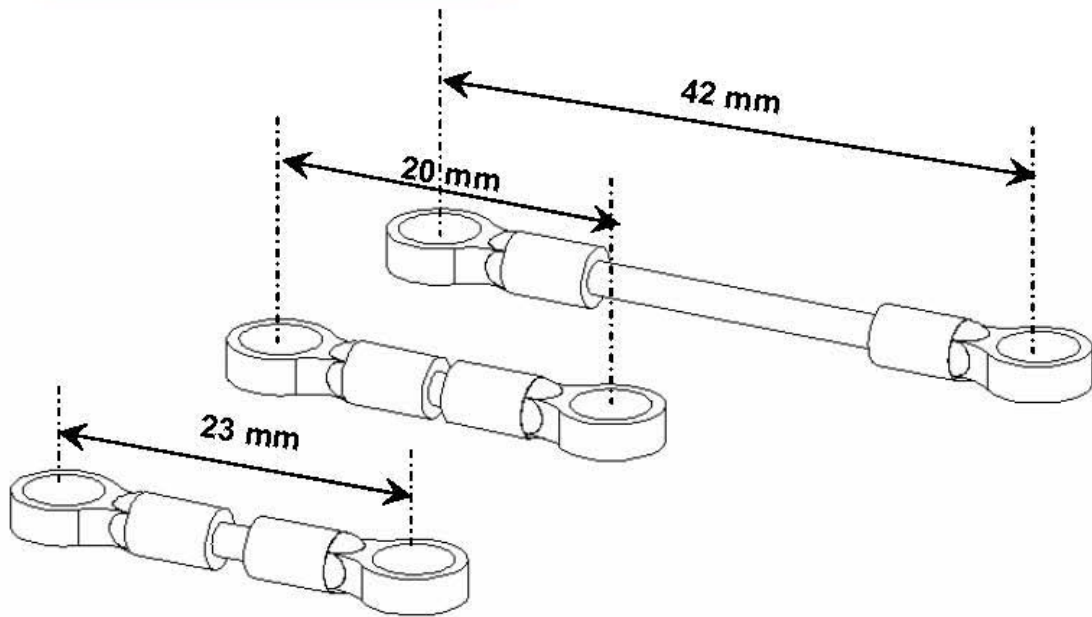

Servo Linkage rod

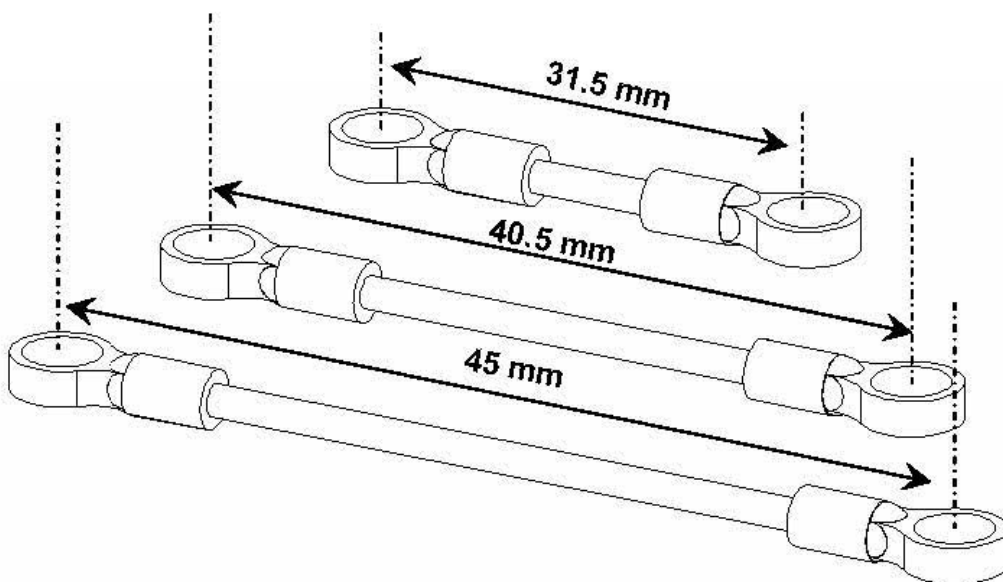

Copter X

450 AE Parts List



CX450-01-00
Main Rotor Head Set



CX450-01-01
Metal Rotor Housing



CX450-01-02
Metal Main Rotor Holder



CX450-01-03
Metal Flybar Seesaw Holder



CX450-01-04
Metal Control Lever



CX450-01-05
Metal Washout Control Arm



CX450-01-06
Metal Washout Base



CX450-01-07
Metal Flybar Control Set



CX450-01-08
CCPM Metal Swashplate



CX450-01-09
Main Shaft



CX450-01-10
Flybar Paddle Set



CX450-01-12
Linkage Rod Set



CX450-01-13
Feathering Shaft



CX450-01-14
Carbon Flybar Paddle



CX450-02-00
Metal Tail Rotor Set



CX450-02-01
Metal Tail Unit



CX450-02-02
Metal Tail Holder Set



CX450-02-04
Metal Tail Rotor Shaft



CX450-02-05
Drive Belt



CX450-02-06
Tail Rotor Control Set V2



CX450-03-00
SE Main Frame Set



CX450-03-01
Tail Boom Lock



CX450-03-02
Main Shaft Locating Set



CX450-03-03
Tail Gear Drive Set



CX450-03-04
Motor Mount

Copter X

450 AE Parts List



CX450-03-05
Carbon Battery
Mounting Plate



CX450-03-06
Carbon Lower
Frame



CX450-03-07
Bottom Plate



CX450-03-08
Frame Hardware Set

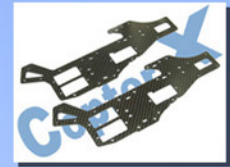

CX450-03-09
Carbon Upper
Frame



CX450-03-10
Aluminum Anti
Rotation Bracket



CX450-03-11
Canopy Mounting Bolt



CX450-03-20
AE Main Frame Set



CX450-03-21
Aluminum Battery
Mounting Plate



CX450-03-22
Aluminum Lower Frame



CX450-03-23
Aluminum Upper Frame



CX450-04-01
Bump Resistance
Landing Skid



CX450-04-02
Landing Skid Pipe



CX450-04-03
Landing Skid Nut



CX450-04-04
Metal Bump
Resistance
Landing Skid



CX450-05-03
High Strength Main
Gear Set V2



CX450-06-01
Wooden Main
Rotor Blade



CX450-06-02
Tail Rotor Blade



CX450-06-03
Carbon
Stabilizer Set



CX450-06-04
Aluminum
Stabilizer Set



CX450-06-05
Carbon Main
Rotor Blade



CX450-06-06
Carbon Tail
Rotor Blade



CX450-06-07
Glass Fiber
Tail Rotor Blade



CX450-07-01
Tail Linkage
Rod



CX450-07-02
Tail Boom
Brace

Copter X

450 AE Parts List



CX450-07-03
Tail boom



CX450-07-04
Aluminum Tail Servo Mount



CX450-07-05
Metal Tail Boom Brace

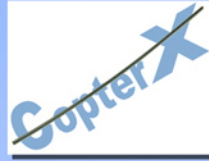

CX450-07-01
Tail Linkage Rod

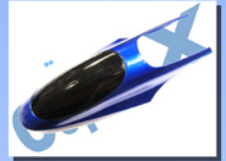

CX450-07-07
Canopy



CX450-07-08
Screws Set



CX450-07-09
Glass Fibre Canopy



CX450-07-10
Glass Fibre Canopy



CX450-07-11
Glass Fibre Canopy



CX450-07-12
Glass Fibre Canopy



CX450-07-13
Glass Fibre Canopy



CX450-07-14
Glass Fibre Canopy



CX450-08-01
Main Blade Holder



CX450-08-02
Full Size Aluminum Case



CX450-08-03
Hook & Loop Fastening Tape



CX450-08-04
Micro Heli Pitch Gauge



CX450-08-05
Ball Link Plier



CX450-08-06
3D Training Kit



CX450-08-07
Hexagon Screw Driver Tools Set



CX450-08-08
Hexagon Screw Driver Tools



CX450-08-09
Servo Extension Leads 100cm



CX450-08-10
Servo Extension Leads 60cm



CX450-08-11
Servo Extension Leads 45cm



CX450-08-13
Deans Ultra T Plug High-Discharge Connector with Heat Shrink Tubing 5 pairs



CX450-08-14
Gold Plated Connectors with Heat Shrink Tubing 6 Pairs

Copter X

450 AE Parts List



CX450-08-15
Blades Balancer



CX450-08-16
Hexagon Screw
Driver Tools Set



CX450-09-01
Bearings(685ZZ)
5x11x5mm



CX450-09-02
Bearings(693ZZ)
3x8x4mm



CX450-09-03
Bearings(MR63ZZ)
3x6x2.5mm



CX450-09-04
Bearings(MR83ZZ)
3x8x3mm



CX450-09-05
Bearings(MR74ZZ)
4x7x2.5mm



CX450-09-06
Bearings(MR52ZZ)
2x5x2.5mm



CX450-10-00
430L Brushless
Motor & 30A
Brushless ESC
with BEC



CX450-10-01
430L Brushless
Motor (3550KV)



CX450-10-02
Motor Pinion
Gear 11T/13T



CX450-10-03
30A Brushless
ESC with BEC



CX450-30-00
Main Rotor
Head Set
- HDE Version



Futaba 6EXH
6-Channel EP
Helicopter
Package

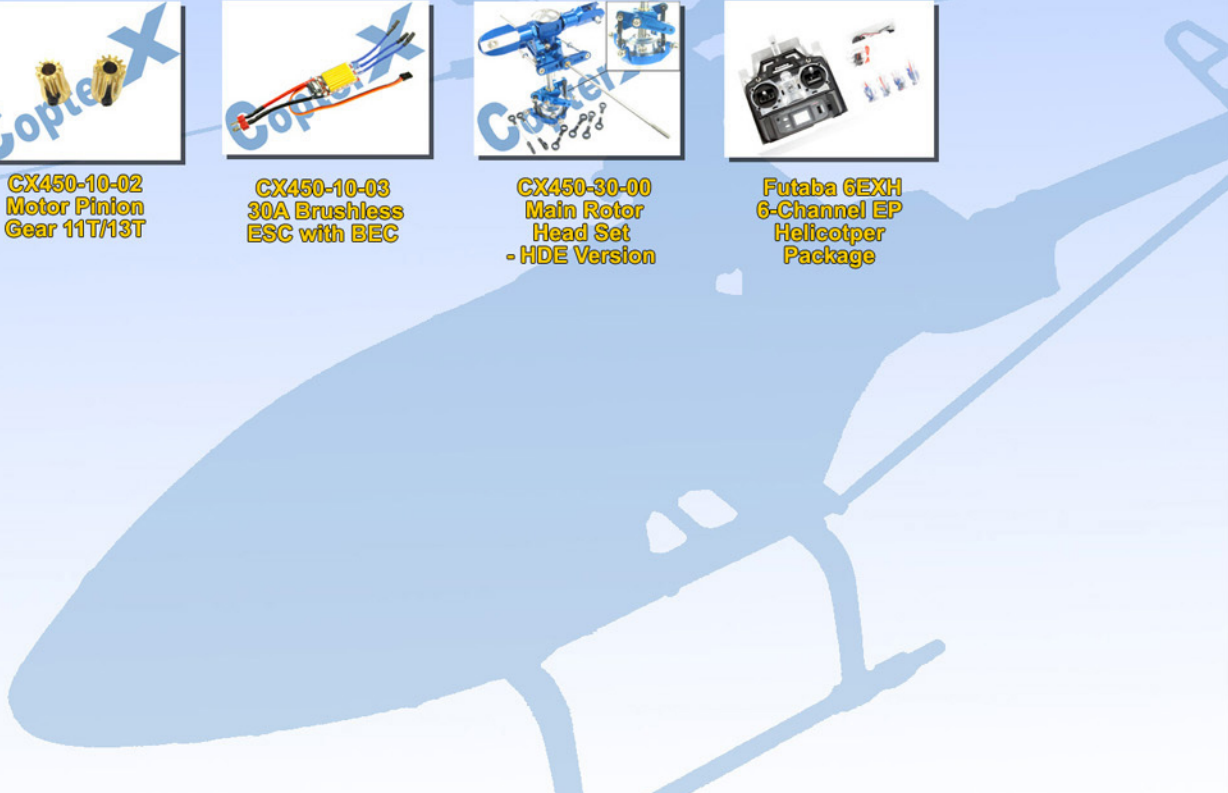

Copter X

450 AEV2 Parts List



CX450-01-20
Main Rotor
Head Set V2



CX450-01-21
Metal Rotor
Housing V2



CX450-01-22
Metal Main
Rotor Holder V2



CX450-01-23
Feathering
Shaft V2



CX450-03-24
Tail Boom
Lock V2



Copter **X** **450SEV2**